

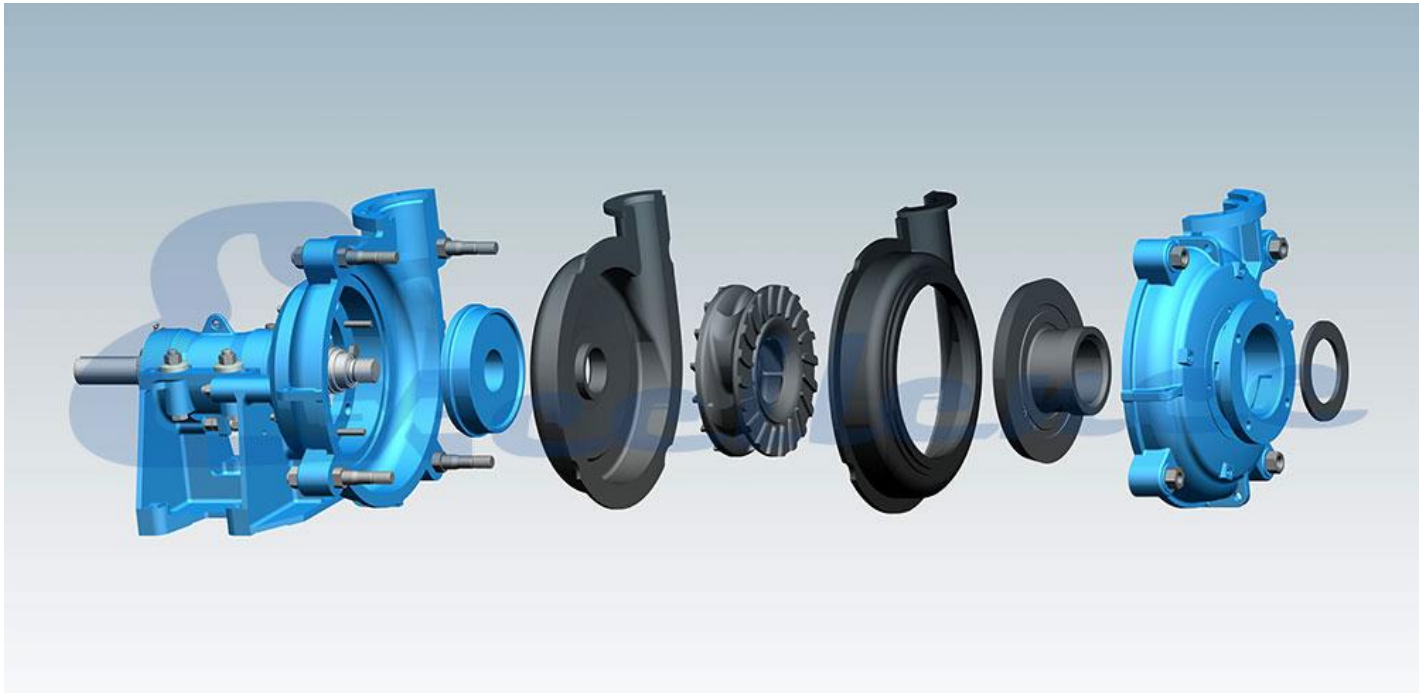

EHR series slurry pumps are similar to EHM series in structure. The main difference between EHM and EHR is the material of wet parts, which are natural rubber, chloroprene rubber or other wear-resistant rubbers. EHR are more suitable in delivering strong corrosive or abrasive slurries of small particle size without sharp edges.



- Frame Plate and Cover Plate: The outer casing is made of grey cast iron or ductile cast iron according to the working pressure, with split with split structure and bolts connected, which ensuring security and easy replacement of the wet parts;
- Interchangeable anti-corrosive wet parts made of natural rubber or other customized elastomer materials;
- The discharge direction can be oriented to any eight positions at the interval of 45 degrees;
- It can be installed in multistage series to meet the delivery for long distance;
- Various drive types: DC(direct connection), V-belt drive, gear box reducer, hydraulic couplings, VFD, SCR control, etc;
- The shaft seal can be packing seal, expeller seal or mechanical seal;
- High efficiency, long lifetime and easy maintenance.

❖ Structure

Series EHR structural drawing:

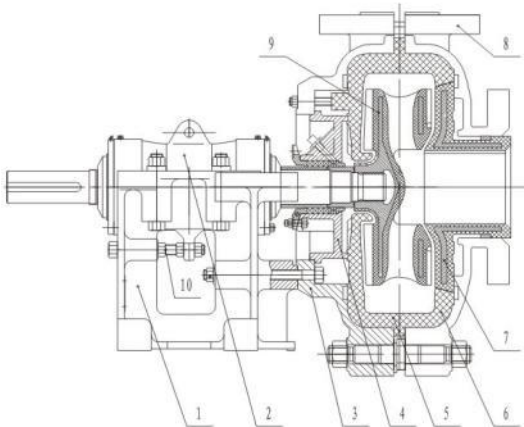

- | | |
|----------------------|----------------------|
| 1. Frame | 6. Cover plate liner |
| 2. Bearing assembly | 7. Throatbush |
| 3. Frame plate | 8. Cover plate |
| 4. Stuffing box | 9. Impeller |
| 5. Frame plate liner | 10. Adjusting bolt |

Note: this is the basic drawing of structure. There would be some differences up to varied discharge size.



EHR-8X

Bearing Assembly

Convenient to adjust the space between impeller and front liner and can be removed completely;

- Lubricated by grease;
- Easy maintenance;

Shaft Seal

There are three standard shaft seal methods:

- Packing seal: it is the lowest in cost.
- Expeller seal: it is most commonly used.
- Mechanical seal: it has best seal effect, but high in cost and has strict requirement of flush water.

Material

The wet parts material for standard EHR series pump is natural rubber. With superb anti-corrosive performance, it is ideal for the delivery of strong corrosive slurry without sharp edge.

- Natural rubber ER01: it is more resistant to both chunking wear and dilation (ie, expansion caused by centrifugal force) than ER02.
- Natural rubber ER02: antioxidants and anti-aging agents are added prolong the storage and usage life of ER02.

❖ Performance Chart

	Allowable Max. Power P(Kw)	Clear Water Performance						Impeller
		Capacity Q		Head H(m)	Speed n(r/min)	Top Efficiency η%	NPSH(m)	Impeller Diameter D(mm)
		m ³ /h	l/s					
EHR-1B	15	10.8-25.2	3-7	7-52	1400-3400	35		
EHR-1.5B	15	25.2-54	7-15	5.5-41	1000-2600	50	2.5-5	178
EHR-2C	30	36-75.6	10-21	13-39	1300-2100	55	2-4	213
EHR-3C	30	79.2-187.2	22-52	5-34.5	800-1800	59	3-5	245
EHR-3D	60							
EHR-4D	60	144-313	40-87	12-45	800-1350	65	3-5	365
EHR-4E	120							
EHR-6E	120	324-713	90-198	7-49	400-1000	65	5-10	510
EHR-6R	300							
EHR-8ST	560	540-1188	150-330	12-50	400-750	75	4-12	686
EHR-10ST	560	720-1620	200-450	7-45	300-650	80	2.5-7.5	762
EHR-12ST	560	1156-2520	321-700	13-14	300-500	79	3-8	965
EHR-14TU	1200	1379-3060	383-850	11-63	250-550	79	4-10	1067

❖ Application

Series EHR slurry pumps are widely used in mining, coal washing, power plant, metallurgy, petrochemical, building material, dredging, and other industrial fields, etc.

Typical Application:

- Iron Ore Dressing Plant
- Copper Concentration Plant
- Gold Mine Concentration Plant
- Molybdenum Concentration Plant
- Potash Fertilizer Plant
- Other Mineral Processing Plants
- Alumina Industry
- Coal Washery
- Power Plant
- Sand Excavation
- Building Material Industry
- Other industries



EHR-4D in the calcium carbonate factory in Asia

*EHR-3C Copper-molybdenum Plant
In Mid-East*



*EHR-3C Copper-molybdenum Plant
In Mid-East*

Headquarter:

Add: No.368, Xinshi North Road, Shijiazhuang, Hebei, China 050091.

Beijing Branch:

Add: No.78, East 4th Ring Middle Road, Beijing, China 100124.

Tel: +86-10-59626498

Fax: +86-10-59626499

For inquiries, please send your emails to sales@excellencepump.com

For customer service, please send your emails to service@excellencepump.com